

Fig. C2: Typical cylinder pressure: p_{GAGE} versus θ (Numerical example)

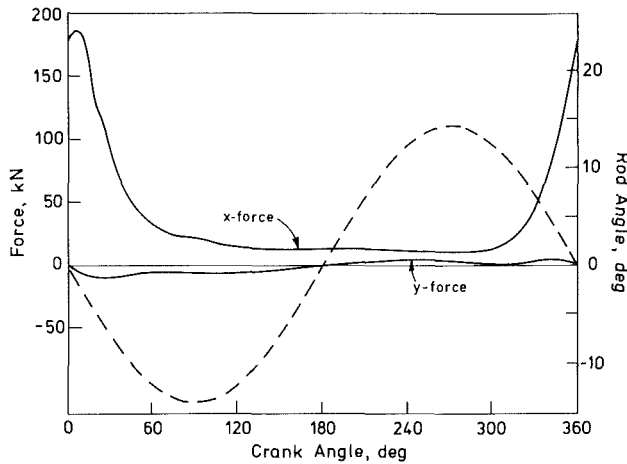

Fig. C3: Duty cycle loading and rotation: F^x, F^y, ϕ versus θ @ $\dot{\theta} = 1900 \cdot 2\pi/60$ rad/s (Numerical example)

Table C1: Typical engine data (for numerical example)

M_{PISTON}	(kg)	4.68
M_{ROD}	(kg)	6.16
I_{ROD}	($kg \cdot m^2$)	0.
d	(m)	0.
r	(m)	0.073
l	(m)	0.305
A	(m^2)	0.0167
$\dot{\theta}$	(rad/s)	$1900 \cdot 2\pi/60$

Kinematics. Figure C1 (b) shows the basic kinematic vector loop equation to have components

$$s = 0 + r \cos\theta + l \cos\phi$$

$$0 = d + r \sin\theta + l \sin\phi$$

DISCUSSION

V. Drei²⁹

I wish to congratulate the authors for their interesting paper dealing with a type of bearing which had not yet been found in the technical literature in so complete and so deep an analysis.

I am particularly interested in the subject because my company already began to study the operating principle of the eccentric type bearing at the end of the sixties, applying it,

Thus it follows that

$$\sin\phi = -(r/l)\sin\theta - d/l$$

$$\cos\phi = (1 - \sin^2\phi)^{1/2}$$

so differentiation gives

$$\frac{d\phi}{d\theta} = -(r/l)\cos\theta/\cos\phi$$

$$\frac{d^2\phi}{d\theta^2} = (r/l)\sin\theta/\cos\phi + (r/l)^2 \cos^2\theta \sin\phi/\cos^3\phi$$

and

$$\frac{ds}{d\theta} = -r(\sin\theta - \cos\theta \sin\phi/\cos\phi)$$

$$\frac{d^2s}{d\theta^2} = -r[\cos\theta + \sin\theta \sin\phi/\cos\phi + (r/l)\cos^2\theta/\cos^3\phi]$$

For usually realized ratios

$$d/l \ll r/l \ll 1$$

it follows that

$$\phi \approx \sin\phi \approx -(r/l)\sin\theta$$

$$\cos\phi \approx 1$$

so

$$\frac{d\phi}{d\theta} \approx -(r/l)\cos\theta$$

$$\frac{d^2\phi}{d\theta^2} \approx (r/l)\sin\theta [1 - (r/l)^2 \cos^2\theta] \approx (r/l)\sin\theta$$

$$\frac{ds}{d\theta} \approx -r \sin\theta [1 + (r/l)\cos\theta] \approx -r \sin\theta$$

$$\frac{d^2s}{d\theta^2} \approx -r[\cos\theta + (r/l)(\cos^2\theta - \sin^2\theta)] \approx -r \cos\theta$$

Example: Two-Stroke Diesel Piston-Pin. Basic data for a typical medium-size two-stroke Diesel engine are given in Table C1 and Fig. C2.²⁸ It is assumed that clearances are such that cross-head bearings do *not* prevent piston side thrust, so that the foregoing analysis is applicable without modification. Resulting computed piston-pin loading and angular motion are shown in Figs. C3.

²⁸The particular engine is a General Motors Detroit Diesel Allison Division turbocharged series 149.

later on, to the crosshead bearings of several large bore two-stroke diesel engines ranging from 600 to 1060 mm bore, for a total of about 370 cylinders now in service.

The solution adopted, shown in Fig. D1, gave a considerable improvement of the load carrying capacity and reliability, enabling also up-rating of the engine without oversizing the crosshead bearings or introducing high pressure oil feeding.

As the authors also proved, the possibility to realize for each segment a relative displacement between journal and

²⁹Manager of Calculation Department, Grandi Motori Trieste, Trieste.

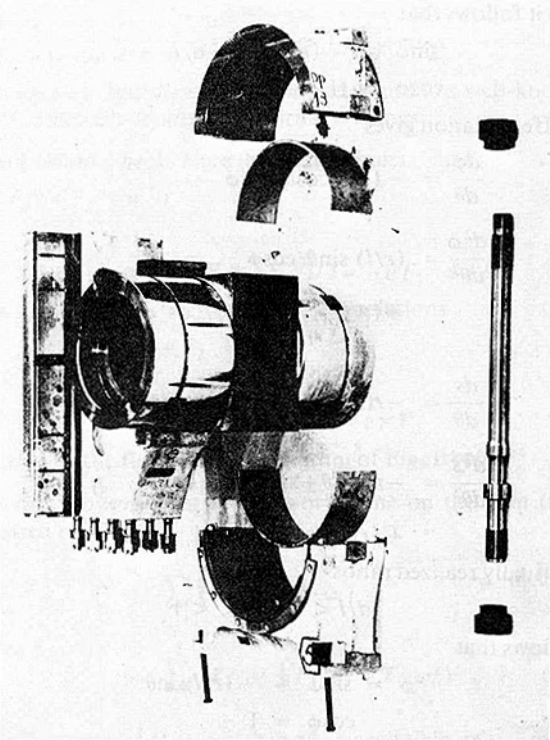

Fig. D1 Eccentric crosshead bearing—main components

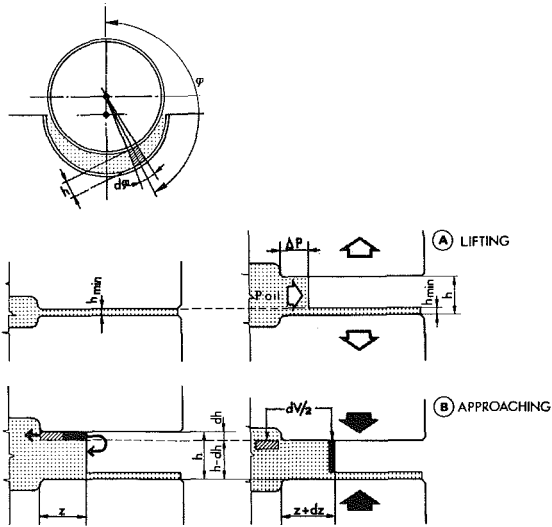

Fig. D2 Simplified model used to calculate oil penetration into the clearance

bearing enables the oil to fill the clearance during this phase and to increase considerably the minimum film thickness.

Moreover, optimizing the maximum displacement value, it is possible to assure the correct bearing lubrication by means of peripheral grooves, eliminating the axial ones traditionally adopted in the crosshead bearings.

With this solution, larger plain surfaces are obtained which further improve the load carrying capacity, but it becomes essential the study of the oil penetration in the clearance during the displacement period.

The problem has been dealt with in a computerized study set by my company in order to calculate the journal path and the operating conditions of such type of bearings.

In order to evaluate the oil penetration and its subsequent smearing inside, the generated volume has been subdivided in longitudinal oil flow ducts in which are supposed viscous laminar conditions, as schematically shown in Fig. D2.

During the volume generation, the oil flows axially under

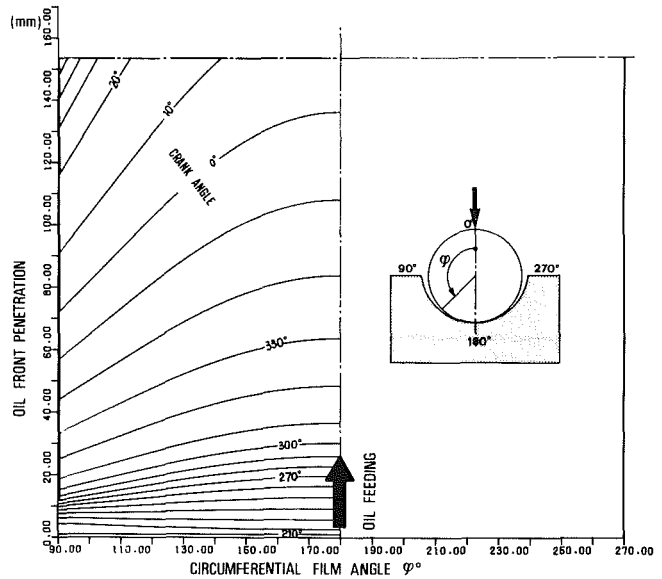

Fig. D3 CC 600 crosshead bearing—calculated front oil penetration in the main central segment

the feeding pressure (phase A), filling then more or less the volume, thanks also to the squeeze effect generated by the relative approaching of the surfaces (phase B).

The optimization of the relevant parameters as eccentricity, filling period, oil pressure and viscosity, enables to obtain the complete filling of the clearance before the maximum load is reached, so having the highest possible load carrying capacity.

As an example, in Fig. D3 is shown the calculated oil front penetration versus crank angle for the crosshead bearing of the CC 600 short stroke engine.

This new design is characterized by a central main segment with high length/diameter ratio and two lateral lifting segments, this arrangement being particularly suited when low dimensions and weight are required.

S. M. Rohde³⁰

The authors are to be congratulated for presenting an analysis of an extremely interesting type of bearing—the rocking chair bearing. Potentially this bearing is of great value in reducing power loss and wear associated with, for example, the wrist pin in two-stroke diesel engines. In this regard, the discussor agrees with the authors that the power loss level shown for the conventional bearing in Table II is probably extremely optimistic. Undoubtedly, the conventional design will be operating for a portion of the cycle in the mixed friction regime. Consequently, the power losses over that period will be considerably higher and will dominate the overall power loss on the duty cycle.

The discussor also agrees with the authors that deformations of the bearing components may be appreciable for the types of loads and operating conditions considered. As was shown in [1], the frictional power loss associated with a conventional journal bearing can go up appreciably due to the “wrapping” of the bearing around the journal. Do the authors have any feel for what the relative performance of the rocking chair design will be when deformations are included? Likewise, with the high pressures that are indicated in the paper, perhaps the effect of pressure on viscosity should be included in the analysis. The approximations used by the authors should remain valid for such computations.

Finally, both this paper and the companion paper by

³⁰Mechanical Research Department, General Motors Research Laboratories, Warren, Mich. 48090.

Goenka and Booker dealing with elliptical bearings essentially consider the macrogeometry effects. Have the authors considered the effects on bearing performance of microgeometry effects? These would include factors such as the peening of surfaces, etc.

Additional Reference

1 Fantino, B., Frene, J., and DuParquet, J., "Elastic Connecting-Rod Bearing with Piezoviscous Lubricant: Analysis of the Steady State Characteristics," *JOURNAL OF LUBRICATION TECHNOLOGY*, Vol. 101, No. 2, Apr. 1979.

J. W. Kannel³¹

My concern is whether a 1.1 μm film can be considered to be significant. Can the generation of a film of this magnitude be considered to be worth the effort required to generate an offset bearing? Can the film be improved by better lubricant selection?

T. Someya³²

The authors are to be congratulated for presenting a nice analysis of rocking journal bearings to which until now not so much attention was paid as to rotating journal bearing. Could I have the authors' comments on the following equation?

[1] If two bearings are operating side by side, as shown in Fig. 1, the pressure at the intermediate circumference does not necessarily vanish as assumed in the present analysis, but it should be so determined that the flow continuity hold [and also pressure]. Only at the free end circumference the pressure must vanish. However, the assumption of vanishing pressure at both ends is much easier to handle than the flow continuity condition. So, my question is, what order of difference in calculated minimum film thickness and maximum pressure may be existing between both boundary conditions.

[2] For rocking journal bearings with small rocking angle and non-reversing load the flooded lubrication is to my opinion not so easy to establish unless one takes care of proper oil feeding [proper grooves, feed pressure]. Do the authors think that through the dual-center design the need for oil feeding can be somewhat relaxed?

Authors' Closure

The present analysis of rocking journal bearings suggests that development of a cyclic "squeeze effect" can produce satisfactory film thicknesses in cases in which a cyclic "wedge effect" cannot (because of insufficient oscillation amplitude and/or frequency). Owing to the resulting thick-film lubrication conditions, demands for special material properties (for surfaces and/or lubricants) should be greatly reduced.

Since application of rocking journal bearings greatly preceded their present analysis, the Discussion by Ing. Drei of Grandi Motori Trieste is most appropriate and greatly appreciated. In particular, the study indicated by Figs. D2 and D3 allows prediction of the oil penetration (filling) necessary for the practical design of these bearings; it forms a welcome complement to the analysis reported in the text of the present paper.

Figure D4 shows schematically an exploded view of a GMT crosshead bearing similar to that illustrated photographically in Fig. D1. The line drawing, however, is grossly exaggerated to show the offset between the centers of the two inner (main) and the two outer (lift) bearings (shown crosshatched for

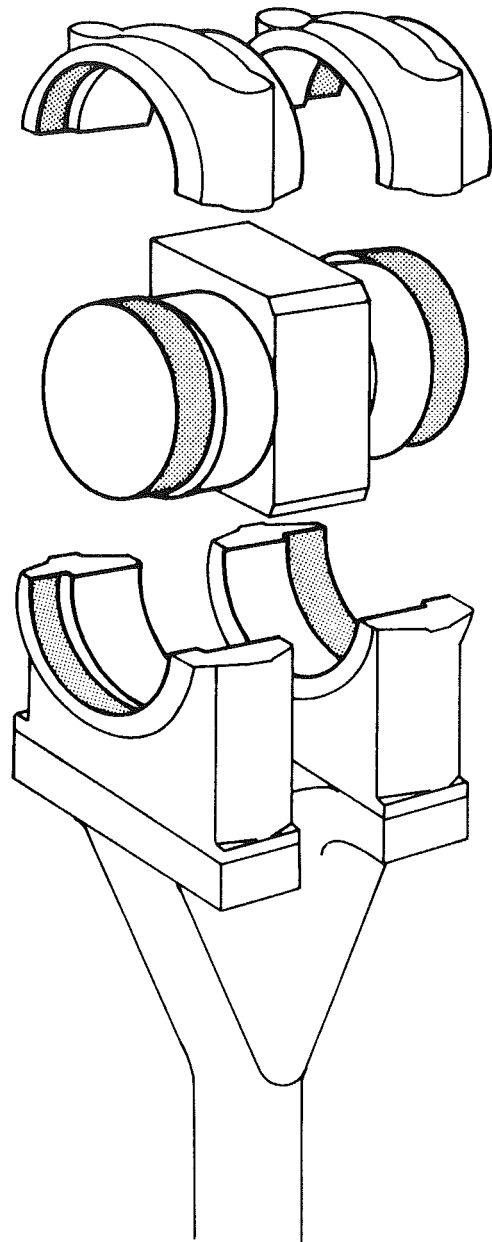

Fig. D4 Offset bearing applied to crosshead of GMT 1060 engine (After Ciliberto and Mariani [1977])

clarity). The drawing also points up the kinematic inversion from the scheme of Fig. 2: that is, in the GMT implementation it is the sleeves which rotate with the connecting rod, while the journals translate with the crosshead (and piston). The rocking principle is precisely the same in both arrangements, and the previous analysis is equally applicable.

Figure D5 shows the results of such an analysis performed in collaboration with Messrs. F. A. Martin, G. Jones, and A. de Segundo of the Glacier Metal Company, the bearing manufacturers for the GMT engine in question.

In Fig. D5 (in contradistinction to Figure 6) the paired offset journal centers are shown fixed, while the paired offset clearance spaces of the sleeves are shown in successive positions through the cycle. In this particular GMT design the pin and sleeve offset directions differ by some 8 deg; correspondingly, the elongated clearance spaces are shown to be quite different for the inner and outer bearings.

Equally well (though not shown here), the same information could be displayed from the viewpoint of an ob-

³¹Battelle, Columbus, Ohio 43201.

³²Professor, Faculty of Engineering, Department of Mechanical Engineering, University of Tokyo, Tokyo, 113 Japan.

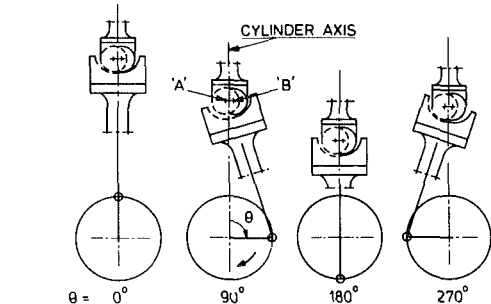
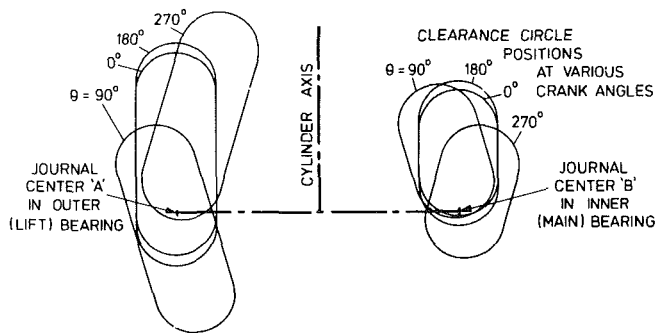

Fig. D5 Clearance space displacement for GMT 1060 engine

server rotating with the sleeve(s), thus showing journal center orbits within the (fixed) clearance spaces as in Fig. 6.

Finally, Fig. D6 shows the variation of minimum film thickness with crank angle as the bulk of the load is taken successively by the inner (main) and outer (lift) bearings. Cusps in the curve thus arise as the locations of minima shift abruptly.

As in the text Example, the minimum film thickness predicted for the GMT offset design is very much greater than that predicted for a similar design without offset. Absolute values shown in Fig. D6 are much greater than those in Fig. 7(b), however, in keeping with a much larger bearing size (680 mm) than that of the Example in Table 1 (61 mm).

Since our analysis of partial arc bearings follows the model established by Rohde and Li [1980], the comments and questions of Dr. Rohde are particularly relevant. Since most of the power dissipation in "rocking chair" (dual-center) designs comes from "squeeze" action, any elastic "wrapping" of the sleeve around the journal may even have a beneficial effect on power dissipation in such cases.¹ As long as the partial arc is short, the effect should be small in any event. Only a complete transient elastohydrodynamic analysis (which we are presently undertaking) will provide any assurance for our speculation, however. Because of the undoubted presence of elastic effects (with their presumed lessening of maximum film pressure), it seems premature to incorporate *only* the additional effect of pressure on viscosity, though that would be straightforward (as noted by Dr. Rohde). The suggested consideration of microgeometry effects we hope to see followed up in future work.

¹ This would contradict the results of Fantino et al. [2] for a stationary case of "wedge" action.

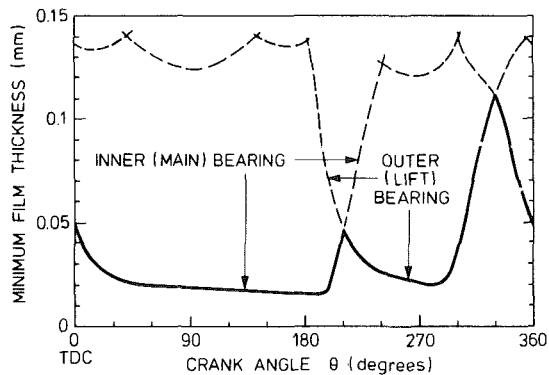

Fig. D6 Minimum film thickness for GMT 1060 engine

Dr. Kannel rightfully questions the adequacy of the computed value of minimum film thickness reported in Table 2 for the "improved" dual-center design. (After all, a *relative* improvement of 6:1 is still worthless if the *absolute* film thickness is still inadequate.) This computed value (1.118 μm) is comparable to danger levels from field experience reported by Warriner [1977] and quoted elsewhere by Booker [1979] for connecting-rod bearings of similar size. However, wrist-pin/cross-head bearings normally are understood to function satisfactorily with much smaller computed film thicknesses than connecting-rod bearings, presumably because of the limited rotation of the former. Clearly, however, the uncertainties involved show once again why computed values should be used only as guides for *comparison* in the light of *comparable* field experience. In this connection the favorable experience reported by Ing. Drei is most comforting.

Prof. Someya calls attention to two important points not made clear in the original paper. Firstly, the existence of circumferential grooves separating bearing segments is implicitly assumed in the Example (and explicitly provided in the GMT design described in Ing. Drei). Secondly, though it appears from the Example that conditions are very much better with the dual-center design, one still must pay attention to the critical matter of proper oil feeding (as addressed by the analysis of Ing. Drei).

Questions raised informally by other readers suggest confusion between the present "rocking" design and the previously described "Camella" bearing [3], in which only the *sleeve* segments are offset. (Of course, the present general analysis could be applied in such a special situation.) Other questions suggest the need for a simple review [4] of pure squeeze action.

Additional References

- 2 Fantino, B., Frene, J., and Du Parquet, J., "Elastic Connecting-Rod Bearing with Piezoviscous Lubricant: Analysis of the Steady-State Characteristics," *ASME JOURNAL OF LUBRICATION TECHNOLOGY*, Vol. 101, No. 2, Apr. 1979, p. 190.
- 3 Unsigned, "Camella Restricted Clearance Bearings," *Engineering*, Sept. 20, 1963, p. 355.
- 4 Booker, J. F., "Squeeze Films and Dynamic Loading," *Theory and Practice of Tribology*, E. R. Booser, Ed., American Society of Lubrication Engineers, CRC Press (in press).